

rEAgenerated Tremolo

EA Tremolo Redesigned

BACKGROUND

A tremolo circuit was presented in Electronics Australia magazine as a “Guitar Preamp and Vibrato”, November 1968 issue. This circuit has been a popular reference design for many DIY projects due to the low complexity and nice sounding result. Most variants remain near to the original design while implementing small tweaks adjusting LFO rate range, depth control, input buffering or adjusting bias for alternative transistor part selection, etc.

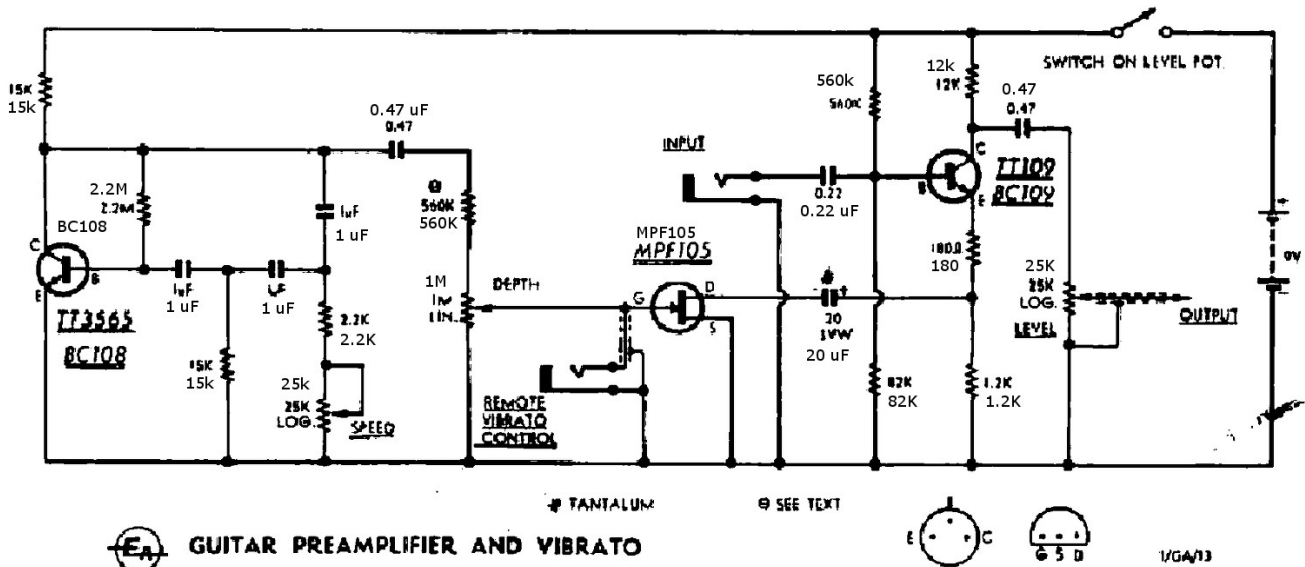

Illustration 1: Original Schematic from Electronics Australia November 1968 Issue

The salient characteristic of the EA tremolo is found in the use of a JFET AC coupled into the emitter of a BJT acting as a voltage controlled resistor. The JFET is then modulated by a phase shift oscillator thereby turning the variable gain stage into an amplitude modulator. The advantage as presented in the original article is that this provides an entirely solid state solution without clumsy optical assemblies. At the time the optical (CdS) cell was modulated by an incandescent lamp which requires a great deal of physical space and power. Battery operation would not be a viable choice for something requiring an incandescent lamp.

Since LED technology has become common and inexpensive an optical solution is not as clumsy as it once was, and with higher efficiency LED's an optical tremolo is even suitable for battery powered applications. This seems to negate the point of building a purely solid state tremolo, but there still remains the characteristic sound due to the modulation shape of the JFET variable resistor element.

Now having established a justification for keeping this old circuit alive one may ask, "If it was good back then, it's still good now – why change it?".

The main motivation is the amount of modulation depth available from the original EA design falls short of what is possible from typical optical or OTA designs.

Often it is asked in the DIY community "I like the EA Tremolo but how do I increase the depth?". The short answer is that you picked the wrong circuit if you want a more extreme effect than what the EA tremolo delivers. Certainly there are ways to mod the circuit to achieve a more prominent effect, but the minimum gain is stuck in place by the emitter resistor in the BJT gain stage. Going the other way, maximum gain is limited by the available headroom before clipping.

There is another answer: Eliminate the emitter bias resistor (fundamentally change the circuit). It is supposed you might have your cake and EA it now.

The bias resistor can be replaced by a transistor acting as a constant current sink providing the correct bias for the gain stage while presenting a very high impedance to the emitter. Upon this basis the rEAgenerated Tremolo is born.

ALL THINGS CONSIDERED

We engineers can't leave well enough alone. The EA was a good design from the start but now that it's out there it appears we can find things need to change. Here is a list of things specifically addressed with the rEAgenerated design:

- Depth: Let's turn this thing into a chopper!
- Backward compatibility: Don't completely break the ability to get that smooth subtle throbbing that is characteristic of the original EA trem.
- Increased Input impedance: Is there a more simple solution than a buffer in front?
- Simplicity: Is there a way to earn back some simplicity after adding some complexity?
- Headroom for the modern FX chain: It is reported to be a relatively clean boost as designed, but given the amount of gain it will break up with a hot signal input (probably with most guitar pickups with volume knobs at max).
- Gain: The original circuit was meant to be a preamp for driving a hi-fi amp while adding the "Vibrato" channel capability found in guitar amps. The more typical use now is a tremolo effect stompbox. The original EA has 26 dB of gain. Gain amplifies noise. Do we really need that much gain?

The below schematic reveals how the above considerations were put into a practical circuit.

THE CIRCUIT: rEA TREMOLO - REGENERATED

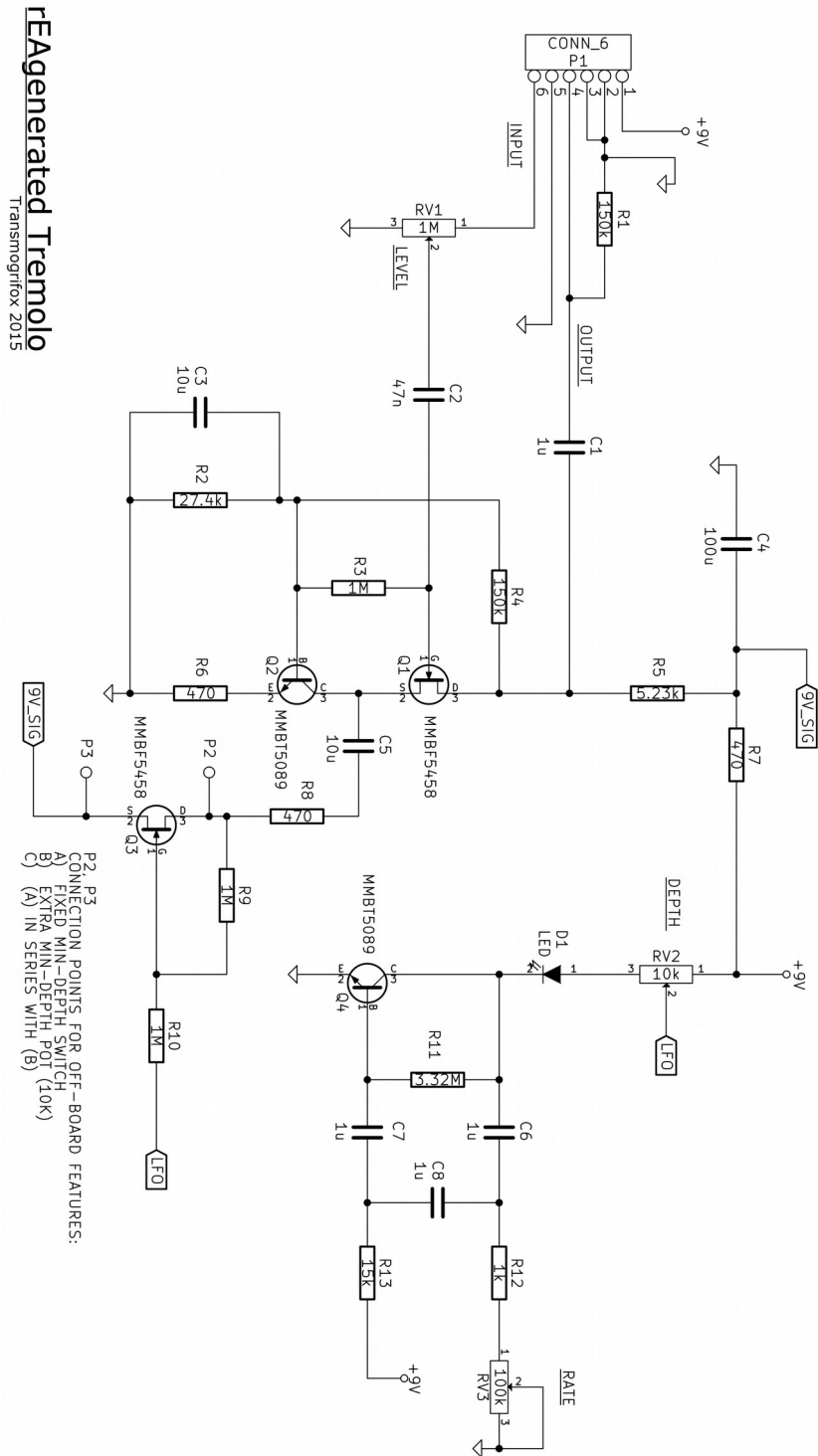

rEAgenerated Tremolo
Transmogrifox 2015

Illustration 2: rEAgenerated Tremolo Rev A

rEAgenerated Tremolo Rev B
Transmogrifox 2015

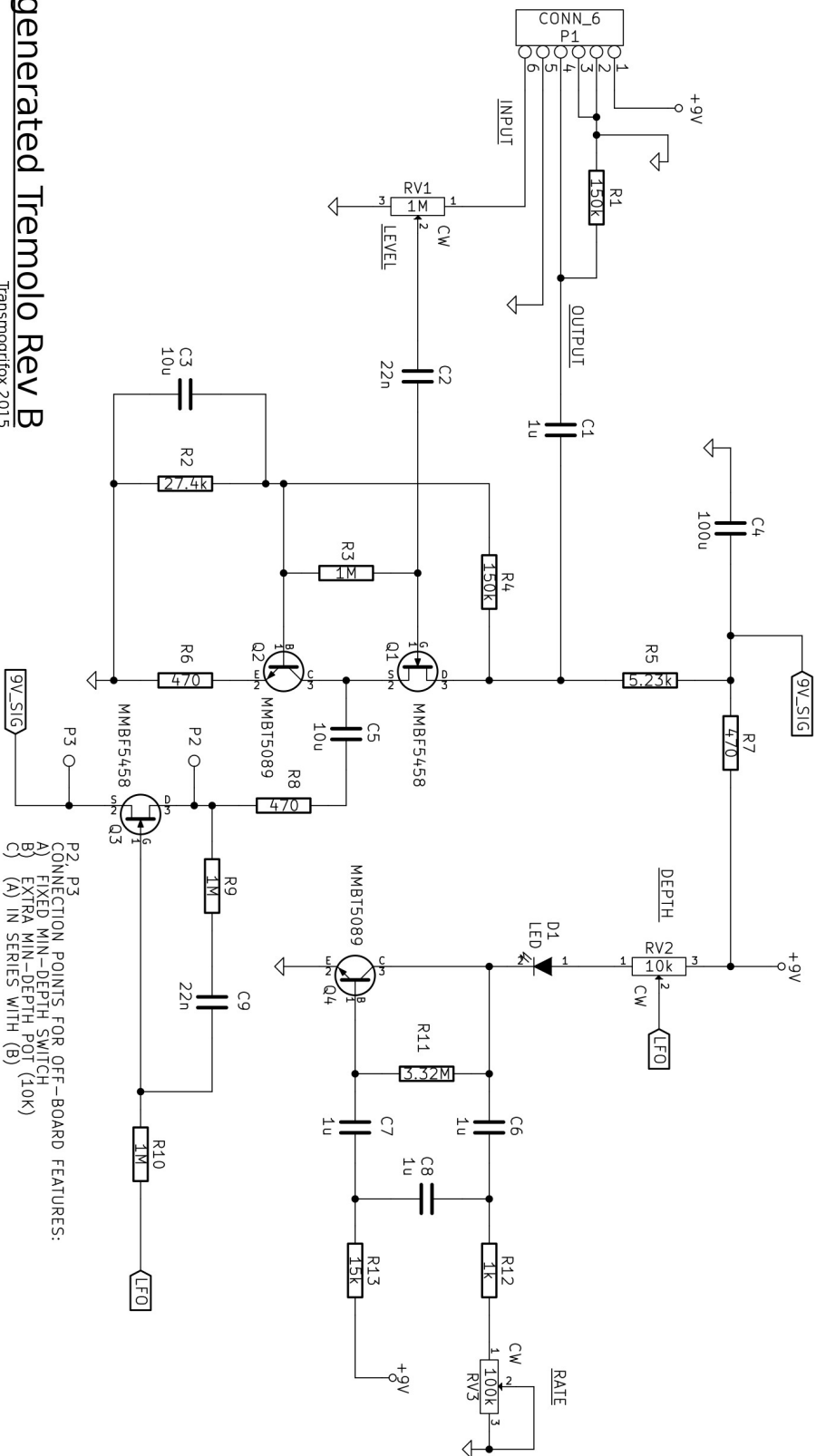

Illustration 3: rEAgenerated Tremolo Rev B C9 to Increases Depth to -58 dB

Note Rev B above came about because further simulation revealed max depth was about 30 dB because the control FET (Q3) was being biased through the LFO. This turned it on and prevented max resistance from going as high as what could be obtained with a FET totally pinched off. For most uses Rev A is a great improvement over the original EA trem as pertains to modulation depth. Here's the summary of modulation depth between versions:

	Modulation Depth
Original EA Design	12 dB
rEAgenerated Rev A	30 dB
rEAgenerated Rev B	60 dB

The list of changes and reasons are as follows. The descriptions are accurate for both Rev A and Rev B.

Change	Reason
Move volume pot to input.	Provides a means to attenuate the input to avoid clipping with hot signals.
Constant Current Sink (Q2)	When JFET Q3 is completely pinched off, the impedance at this node is very high. This allows for signal attenuation to a level that is practically inaudible (improved depth).
Gain Change (R5,R8)	R5 was selected to be approximately 1/10th of a DI box input impedance (50k to 55k). R8 was adjusted to achieve a gain of 5. This translates to approximately unity gain on an Audio Taper pot when centered.
Linearized FET as variable resistor (Q3)	This type of FET connection is common in other circuits using the FET as a voltage controlled resistance element. Credit for this improvement dates back to AM radio AGC circuits. Rev B AC couples this resistor so that Q3 is not DC biased, which allows it to completely pinch off.
Removed AC coupling to FET gate	It was observed some components can be eliminated by simply referencing Q3 to the 9V supply.
R7, C4 Noise Filtering	More of a "Good Idea" best practice solution. This 470 + 100 uF combination provides about -30 dB attenuation at 120 Hz. This means 35 mV ripple at 120 Hz will be about 1 mV at the input of your next effect. Pretty much inaudible unless followed by a high gain pedal. Then you may want to be more aggressive or, better, use a cleaner power supply. It's an enormous improvement on the original EA circuit in the realm of power supply noise rejection.
Oscillator Rate Pot increased	Wider range of speed control. This was inherited from GeneralGuitarGadgets improved version.
LED Blinking Indicator	Credit due to somebody who is not me. A nice clever trick to include LED indication of LFO rate. Off-board switch wiring can be used to short it when the effect is bypassed (if desired).
P2,P3 offboard connection points	The main purpose is to allow a pot to be placed between these points to dial in sounds closer to the original EA Tremolo when depth is set near max.

HOW DO I BUILD THIS THING?

This document is aimed at the intermediate builder who can read schematics and develop his/her own layout. Details about how input/output jacks connect to the header, how to externally wire the pots and wire in a battery clip and DC jack are not within the scope of this document.

Below is a bill of materials based on a surface mount component PCB design. The equivalent through-hole parts can be selected for a through-hole layout. I have completed an SMT PCB design and have included both the KiCAD project and Gerber files on my web site. This is an open hardware project so these files can be freely re-distributed and used in whatever fashion is desired.

Some things to note:

- Parts cost is based on the cost per part when purchased in quantities of 10. It's slightly more per unit for a 1-off project.
- Parts cost is Mouser electronics pricing at the time of this writing. It just gives an idea of what it may cost to finish this project.
- Changing C4 (100 uF) to a cheap electrolytic would be a good thing for the thrifty considering the cost of this one part equals the sum of all other passive components on the board. If using my layout, the electrolytic 100 uF cap can be shoe-horned onto the SMT pads. If using your own layout then it's a simple matter of changing the footprint.
- Stomp switch, battery clip and DC power jack not included in BOM. Circuits for this auxiliary stuff are prolific and all but beginners will not have trouble finding suitable parts for these functions. If you are an absolute beginner then help is not far away. Probably a better step-by-step build project is more appropriate for a first timer.

BILL OF MATERIALS

Part	Value	Comments	Mouser Part#	Price/10
C9	22n	0603 SMT Capacitor, 25V, 10%	81-GRM39X223K25D	0.034
C2	22n	0603 SMT Capacitor, 25V, 10%	81-GRM39X223K25D	0.034
C1	1u	0603 SMT Capacitor, 16V, 10%	81-GRM39R105K16	0.023
C6	1u	0603 SMT Capacitor, 16V, 10%	81-GRM39R105K16	0.023
C7	1u	0603 SMT Capacitor, 16V, 10%	81-GRM39R105K16	0.023
C8	1u	0603 SMT Capacitor, 16V, 10%	81-GRM39R105K16	0.023
C3	10u	0603 SMT Capacitor, 16V, 20%	81-GRM188R61C106MALD	0.195
C5	10u	0603 SMT Capacitor, 16V, 20%	81-GRM188R61C106MALD	0.195
C4	100u	1210 SMT Capacitor, 16V, 20%	80-C1210C107M4PACTU	1.93
R6	470	0603 SMT Resistor, 1/16W, 1%	71-CRCW0603-470-E3	0.044
R7	470	0603 SMT Resistor, 1/16W, 1%	71-CRCW0603-470-E3	0.044
R8	470	603 SMT Resistor, 1/16W, 1%	71-CRCW0603-470-E3	0.044
R12	1k	603 SMT Resistor, 1/16W, 1%	71-CRCW0603-1.0K-E3	0.044
R13	15k	603 SMT Resistor, 1/16W, 1%	71-CRCW0603-15K-E3	0.044
R5	5.23k	603 SMT Resistor, 1/16W, 1%	71-CRCW0603-5.23K-E3	0.044
R2	27.4k	603 SMT Resistor, 1/16W, 1%	71-CRCW0603-27.4K-E3	0.044
R1	150k	603 SMT Resistor, 1/16W, 1%	71-CRCW0603-150K-E3	0.044
R4	150k	603 SMT Resistor, 1/16W, 1%	71-CRCW0603-150K-E3	0.044
R3	1M	603 SMT Resistor, 1/16W, 1%	71-CRCW0603-1.0M-E3	0.044
R9	1M	603 SMT Resistor, 1/16W, 1%	71-CRCW0603-1.0M-E3	0.044
R10	1M	603 SMT Resistor, 1/16W, 1%	71-CRCW0603-1.0M-E3	0.044
R11	3.32M	603 SMT Resistor, 1/16W, 1%	71-CRCW0603-3.32M-E3	0.044
RV2	10k	3-pin header to offboard panel mounted pot	652-PDA241HRT02103A2	2.94
RV3	100k	3-pin header to offboard panel mounted pot	652-PDA241HRT02104A2	2.79
RV1	1M	3-pin header to offboard panel mounted pot	652-PDA241HRT02105A2	3.36
Q1	MMBF5458	Substitution of most small signal JFETs acceptable. May change gain somewhat.	512-MMBF5458	0.267
Q2	MMBT5089	2N3904, 2N5088, 2N5089, 2N2222 all work in simulation	512-MMBT5089	0.14
Q3	MMBF5458	FET choice will change duty cycle and amount of useful depth pot control	512-MMBF5458	0.267
Q4	MMBT5089	Most BJT substitutions ok. May need to adjust R11.	512-MMBT5089	0.14
D1	LED	This may be easily wired to offboard LED	696-SSF-LX453GD-99	0.36
P1	CONN_6	6-Pin header or direct wiring to pads ok		
PCB				
Jacks	Offboard	1/4" Audio Jack	568-NYS229	1.772
Enclosure	1590B	Hammond 1590B	546-1590B	6.22
			Total	21.274