

Bela to Arduino Audio Amplifier:

0.5 Vpp input to 2.5Vpp balanced for 0V to 5V

1. Schematic Diagram

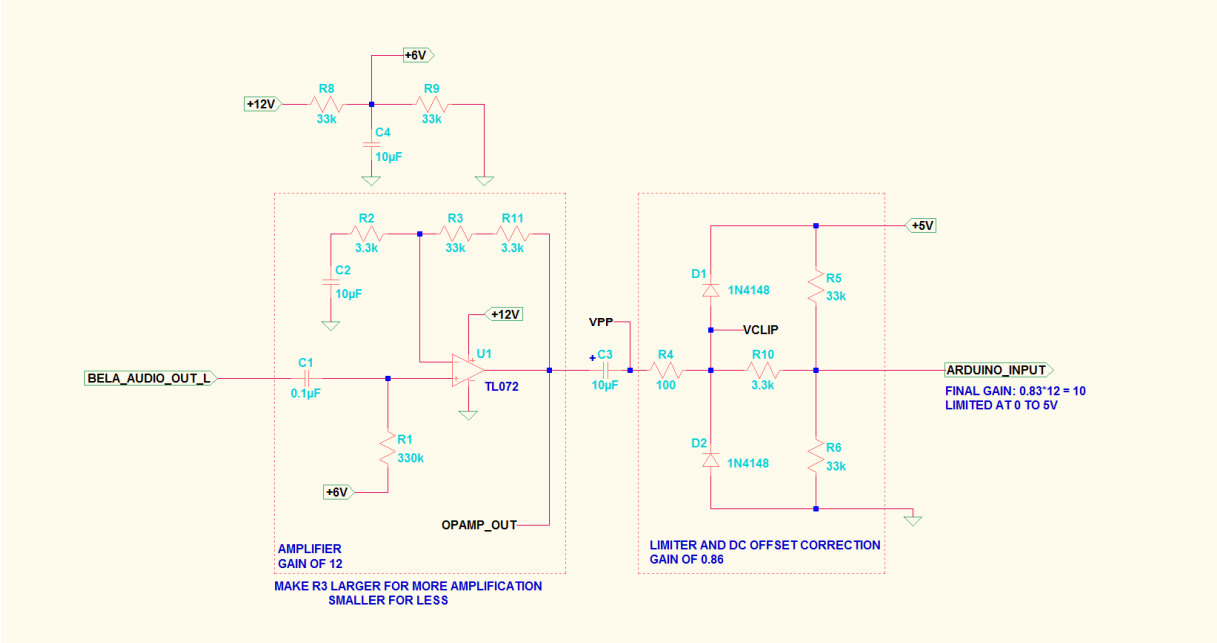

Figure 1-1 Circuit Connecting and Protecting an input receiving 0V to 5V range

2. Simulation Output: 0.5 Vpp input

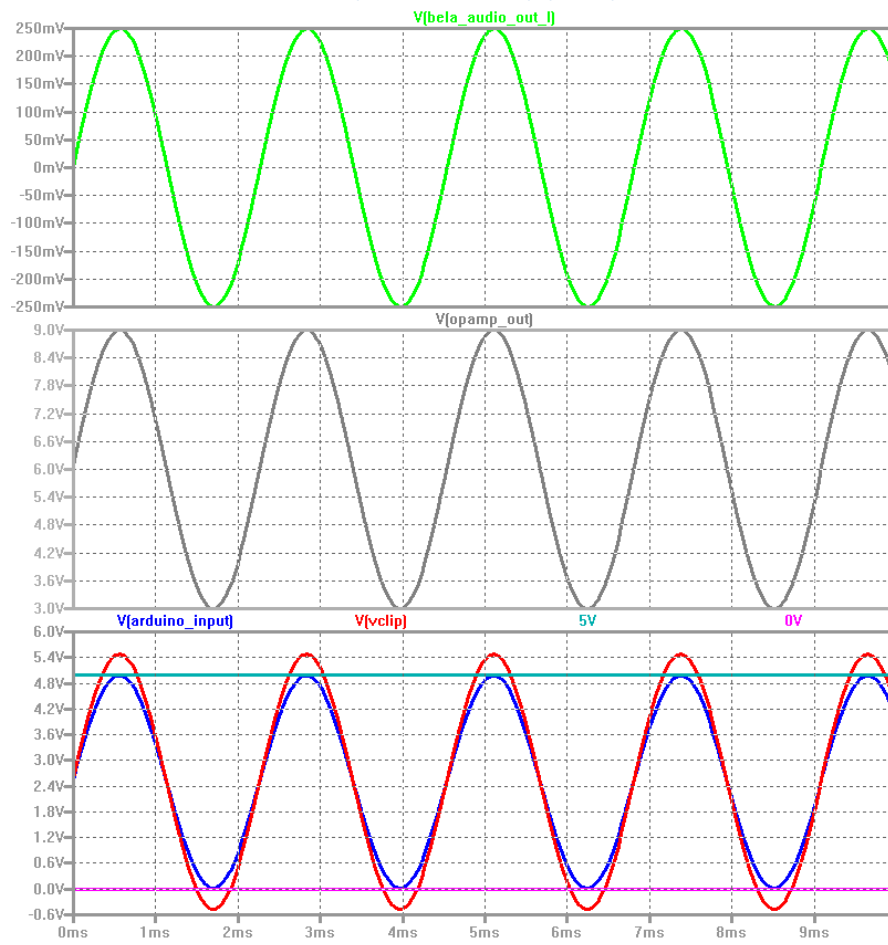

Figure 2-1 Final output is 10xInput

3. Simulation Output: 1.0 Vpp input

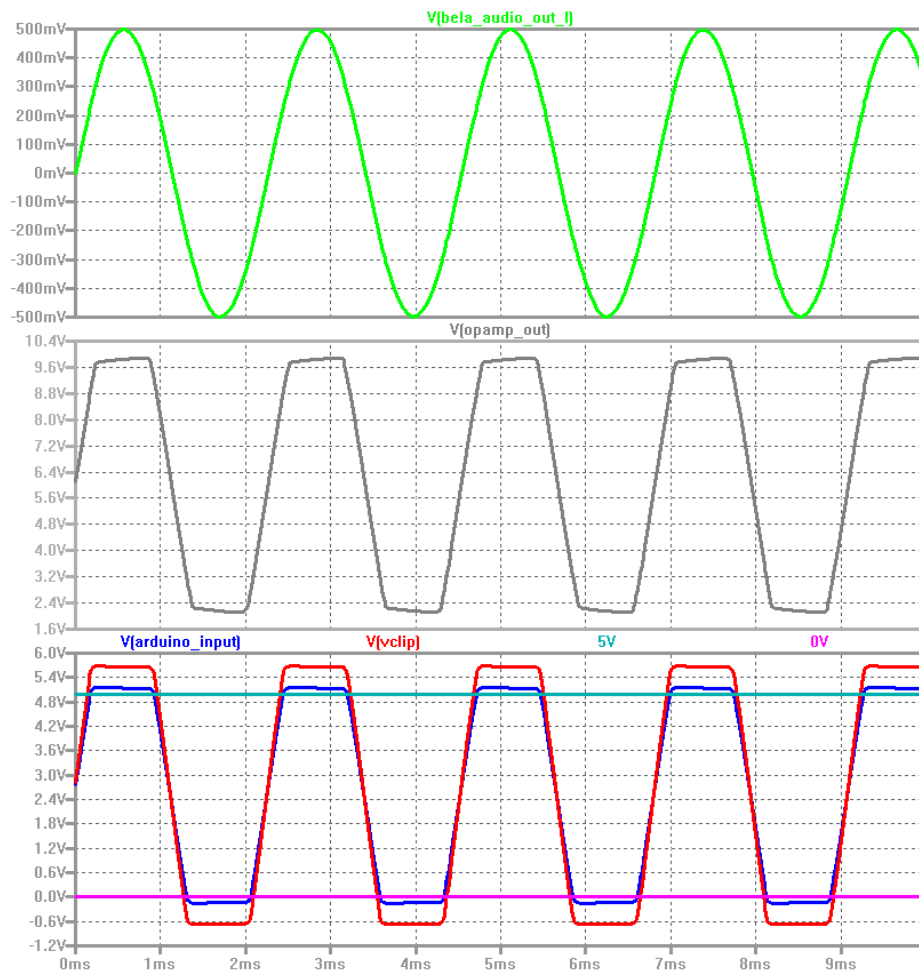

Figure 3-1 The 3rd pane down demonstrates the input protection function of the diodes